

INTRODUCTION

T60 is an electric tow tractor with rated capacity of 6000kg. The compact design and excellent flexibility are suitable for any tight areas. Equipped with powerful batteries and the operation is stable and reliable.



T60N



Electric Sit-on TOW Tractor with capacity of 6000kg

ADVANTAGES

- Compact design and beautiful appearance
- Small turning radius
- Good mechanical performance and no pollution
- Low center of gravity, good stability when turning and driving
- Long service life
- Operating efficiency is high



Nice looking instrument

Nice looking multi-function LCD instrument, which can show large amount of information; using branded motor which has high efficiency and reliable performance.



Comfortable operation

Spacious operation space and low position pedal which make convenient operation.



Security

Emergency cut-off switch can ensure the safety of driving.

- Tractor dedicated gearbox and drive axle assembly, both of them have compact structure and smooth transmission.

- The switch on the left side of the truck has inching function, which has high work efficiency.

- Brand new AC power system provides powerful motivation, more precise control of motor speed performance and various regeneration function, safer and reliable operation.

- Maintenance free AC motor, which can reduce maintenance costs, leave out multiple contactor of DC electric control, improve the reliability. AC power system greatly increase reliability and service life with its high efficiency and complete protection function.





Type sheet for industrial tractor acc. to VDI 2198 1KG=2.2LB 1INCH=25.4MM

Distinguishing mark	1.2	Manufacturer's type designation		T 60N
	1.3	Power (battery ,diesel, petrol gas, manual)		Electric
	1.4	Operator type		Seat
	1.5	Load Capacity / rated load	Q(t)	6.0
	1.7	Rated drawbar pull	F(N)	1500
	1.8	Largest traction	F(N)	4500
Weight	1.9	Wheelbase	Y(mm)	1222
	2.1	Service weight	kg	1500
Wheel chassis	3.1	Tires		Rubber wheel
	3.2	Tire size, front	ø x w (mm)	6.50-10
	3.3	Tire size, rear	ø x w (mm)	4.00-8
	3.5	Wheels, number front/rear(x=driven wheels)		2x/1
	3.6	Tread, front	b10(mm)	/
Tires, Chassis	3.7	Tread, rear	b11(mm)	893
	4.9	Height of tiller in drive position min./ max.	h14 (mm)	1375
	4.19	Overall length	l1 (mm)	2020
	4.21	Overall width	b1 (mm)	1140
	4.32	Ground clearance, centre of wheelbase	m2 (mm)	135
Performance data	4.35	Turning radius	Wa (mm)	1550
	5.1	Travel speed, laden/ unladen	km/h	9.0/13
E- Motor	5.10	Service brake		Electromagnetic
	6.1	Drive motor rating S2 60min	kW	6.8
	6.3	Battery acc. to DIN 43531/ 35/ 36 A, B, C, no		DIN
	6.4	Battery voltage, nominal capacity K5	V/Ah	48/300
	6.5	Battery weight	kg	AC-Speed control
Addition data	8.1	Type of drive control		8.1
	8.4	Sound level at driver's ear acc. to EN 12053	dB(A)	<70

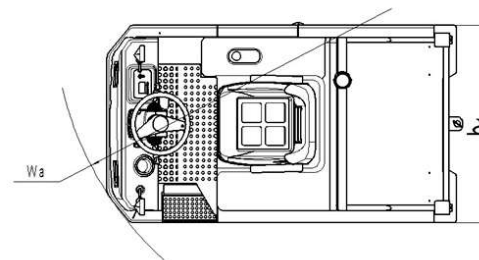
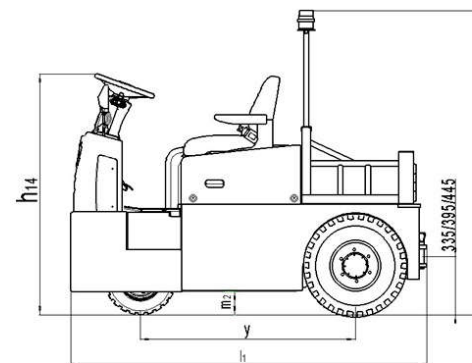

Camel Series